

G FLUSH WALL DETAIL

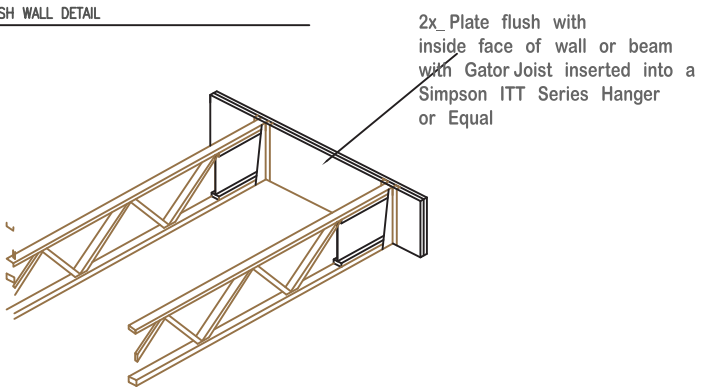

H LOAD BEARING CANTILEVER

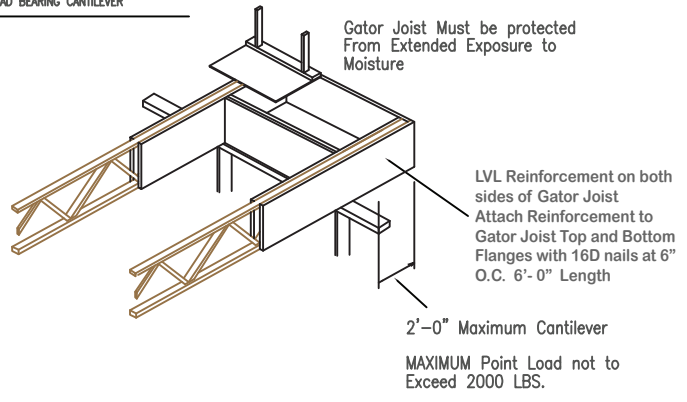

J EXCESSIVE LOAD TRANSFER 4400# +

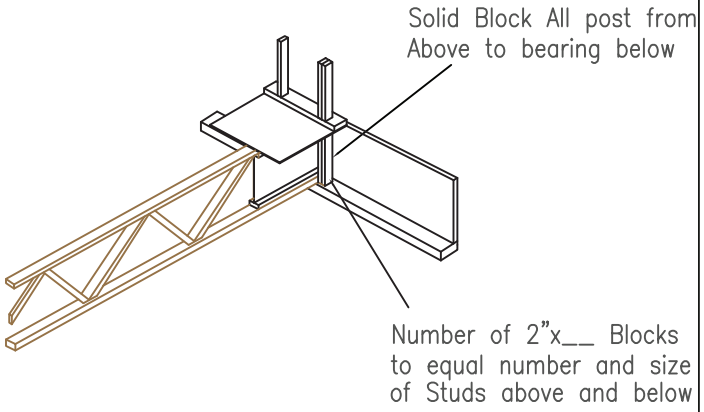

K OVERLAP DETAIL AT INTERIOR BEARING

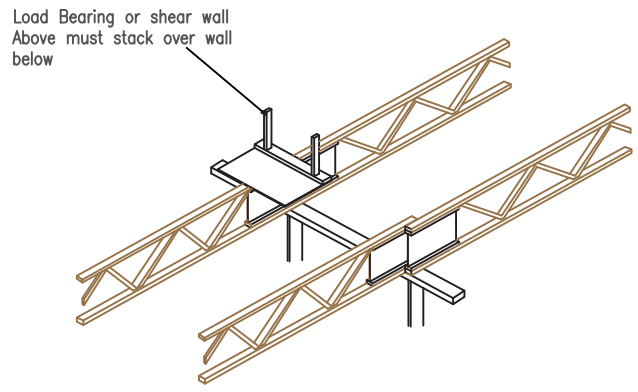

L INTERIOR BEARING CONDITION

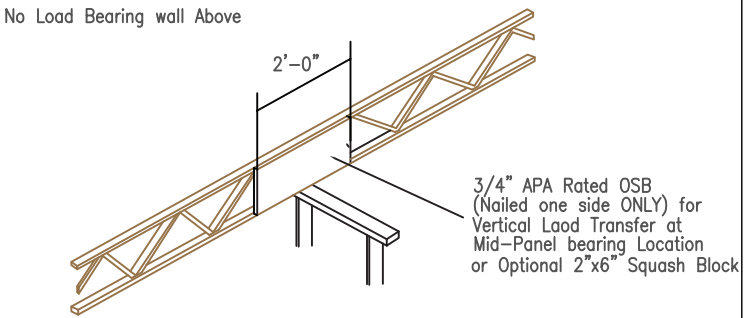

M DROP BALCONY WITH CANTILEVER

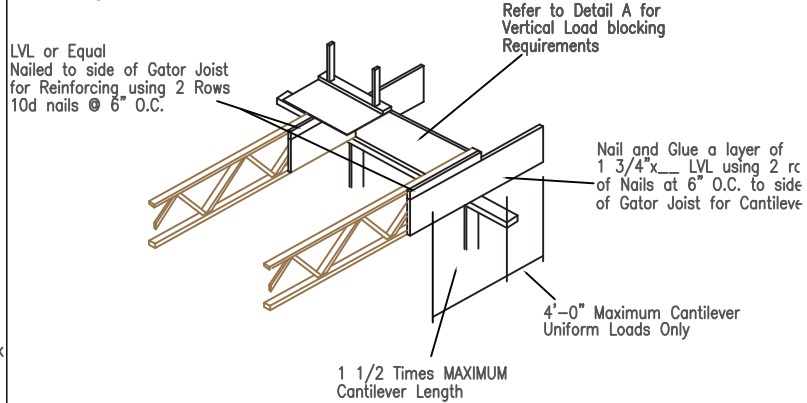

RC RAFTER CUT DETAIL

MINIMUM HEEL HEIGHT	MINIMUM ROOF PITCH	ANGLE IN DEGREES
4 1/4"	12	45°
6 9/16"	10	40°
7 15/16"	9	36.75°
9 1/8"	8	33.75°
10 3/8"	7	30.25°
11 9/16"	6	26.5°

